

2025 Annual Water Quality Report
Hadnot Point Water Treatment System

PWSID # 04-67-041



Marine Corps Installations East-Marine Corps Base Camp Lejeune (Camp Lejeune) is pleased to present the Annual Water Quality Report (Consumer Confidence Report). This report provides details about where your water comes from, what it contains, and how it compares to standards set by regulatory agencies.

This is an annual report of the water quality from January 1 to December 31, 2025

Camp Lejeune is committed to providing you with information because informed customers are our best allies.

Source Water

Twenty-nine drinking water supply wells provide groundwater from the Castle Hayne Aquifer to the Hadnot Point Water Treatment Plant (WTP). There, the raw water is treated by disinfection, softening, and filtration practices prior to distribution to our customers.

Report Summary

This **Annual Report** updates the water quality information gathered since the last interim report was issued in December 2025. Specifically, this report summarizes voluntary and compliance sampling data received during the January to December 2025 period. Camp Lejeune has no violations or Action Level Exceedances to report during this period.

Distribution

Please share this information with anyone who drinks this water (or their guardians), especially those who may not have received this report directly (for example, people in apartments, nursing homes, schools, and businesses). You can do this by posting this report in a public place or distributing copies by hand, mail, email, or another method.

For more information about this report, or for any questions relating to your drinking water, please call David Towler (EMD) at 910-451-9385. This report can be viewed at:

[Camp Lejeune Water Quality Reports](#)

If you prefer a paper copy of the this Water Quality Report, please call 910-451-5003.



MARINE CORPS BASE
CAMP LEJEUNE
"Home of Expeditionary Forces in Readiness"

DISTRIBUTION STATEMENT A: Approved for public release; distribution is unlimited.

Important Drinking Water Terms and Definitions

Term	Definition
AL	Action Level: The concentration of a contaminant which, if exceeded, triggers treatment or other requirements which a water system must follow.
Contaminant	Any physical, chemical, biological, or radiological substance or matter in water.
HAA	Halo Acetic Acids: Chlorine from the water disinfection process can react with organic matter and small amounts of bromide present in water to produce various HAAs.
Herbicide	Any chemical(s) used to control unwanted vegetation.
HI	The Hazard Index is an approach that determines the health concerns associated with mixtures of certain PFAS in finished drinking water. Low levels of multiple PFAS, that individually would not likely result in adverse health effects, may pose health concerns when combined in a mixture. The Hazard Index MCL represents the maximum level for mixtures of PFHxS, PFNA, HFPO-DA (Gen-X), and/or PFBS allowed in water delivered by a public water system. A Hazard Index greater than 1 requires a system to take action.
MCL	Maximum Contaminant Level: The highest level of a contaminant that is allowed in drinking water. MCL's are set as close to the MCLG's as feasible using the best available treatment technology.
MCLG	Maximum Contaminant Level Goal: The level of a contaminant in drinking water below which there is no known or expected risk to health. MCLG's allow for a margin of safety.
MRDL	Maximum Residual Disinfectant Level: The highest level of a disinfectant allowed in drinking water. There is convincing evidence that addition of a disinfectant is necessary for control of microbial contaminants.
MRDLG	Maximum Residual Disinfection Level Goal: The level of a drinking water disinfectant below which there is no known or expected risk to health. MRDLG's do not reflect the benefits of the use of disinfectants to control microbial contaminants.
NA	Not Applicable: Information not applicable / not required for that particular water system or for that particular rule.
Pesticide	Generally, any substance or mixture of substances intended for preventing, destroying, repelling, or mitigating any pest.
SDWA	Safe Drinking Water Act: The federal law that protects public drinking water supplies throughout the nation.
TT	Treatment Technique: A required process intended to reduce the level of a contaminant in drinking water.
UCMR	Unregulated Contaminant Monitoring Rule: Monitoring used by the EPA to collect data for contaminants that are suspected to be present in drinking water and do not have health-based standards set under the SDWA.

Unit Descriptions

Term	Definition
ppm	ppm: parts per million, or milligrams per liter (mg/L)
ppb	ppb: parts per billion, or micrograms per liter (ug/L)
ppt	ppt: parts per trillion, or nanograms per liter (ng/L)

Water Quality Data

The Hadnot Point water distribution system met all Federal and State drinking water standards in 2025. Camp Lejeune routinely monitors drinking water quality for more than 190 substances that may be in your drinking water. The information below lists all of the regulated drinking water substances that were detected in recent water quality sampling. The detected substances do not necessarily affect health. **Unless otherwise noted, the information below is from testing done January 1 through December 31, 2025.** The EPA and the State allow us to monitor certain substances less than once per year because the concentrations of those substances are not expected to vary significantly from year to year. Some of the information below, though representative of the water quality, is more than one year old. Other information presented in this report is from recent monitoring. Although many more substances were tested, only those substances listed below were detected in your water.

Compliance Monitoring

Camp Lejeune sampled the Hadnot Point water system for compliance for Synthetic Organic Compounds (SOCs), Volatile Organic Compounds (VOCs), Radiologicals, and Nitrate-Nitrite during 2024. All sample results were non-detect (ND). Inorganic Compounds and were also sampled with the detections noted below. All results were within established regulatory limits.

Inorganic Contaminants

Regulated Contaminants	MCLG or MRDLG	MCL, TT OR MRDL	Amount Detected	Range		Year Sampled	Violations	Typical Source
				Low	High			
Fluoride (ppm)	4	4	0.54	NA		2024	No	Erosion of natural deposits, water additive which promotes strong teeth, discharge from fertilizer and aluminum factories.
Sulfate (ppm)	NA	NA	4.8	NA		2024	No	Naturally occurring in the environment.
Sodium (ppm)	NA	NA	11	NA		2024	No	Naturally occurring in the environment. Adequate levels of sodium are required for good health.

Disinfectants & Disinfection By-Products

Regulated Contaminants	MCLG or MRDLG	MCL, TT OR MRDL	Amount Detected	Range		Year Sampled	MCL or MRDL Violations	Typical Source
				Low	High			
Chlorine (ppm)	4	4	1.48 ¹	0.34	2.19	2025	No	Water additive used to control microbes
Haloacetic Acids (HAA5) (ppb)	NA	60 (LRAA)	21 ²	7	38	2025	No	By-product of drinking water disinfection
Total Trihalomethanes (TTHMs) (ppb)	NA	80 (LRAA)	63 ²	27	94 ³	2025	No	By-product of drinking water disinfection

¹ Result reported is the Running Annual Average (RAA), which is the average of the sample analytical results from the previous four calendar quarters.

Minimum of 0.2 ppm disinfectant residual concentration required.

² Result reported is the highest Locational Running Annual Average (LRAA), which is the average of the sample analytical results for samples taken at a particular monitoring location during the previous four calendar quarters under the Stage 2 Disinfection and Disinfectant Byproducts Rule.

³ Some people who drink water containing trihalomethanes in excess of the MCL over many years may experience problems with their liver, kidneys, or central nervous systems, and may have an increased risk of getting cancer.

UCMR5 Monitoring

Camp Lejeune conducted additional monitoring as part of Phase 5 of the EPA's Unregulated Contaminant Monitoring Rule (UCMR5). The purpose of unregulated contaminant monitoring is to assist EPA in determining the occurrence of unregulated contaminants in drinking water and whether future regulations are warranted.

UCMR5 specifies monitoring for 29 per- and polyfluoroalkyl substances (PFAS) and lithium. There were no detections of any UCMR 5 constituents in the Hadnot Point drinking water system. For more information about the UCMR please visit:

<https://www.epa.gov/dwucmr>

Inorganic Contaminants

Regulated Contaminants (Units)	Sample Date	Your Water (90th Percentile)	# Sites found above the AL	Range		MCLG	AL	Likely Sources of Lead and Copper
				Low	High			
Copper (ppm)	2023	<0.050 ⁴	0	ND	ND	1.3	1.3	Corrosion of household plumbing systems, erosion of natural deposits
Lead (ppb)	2023	4 ⁴	0	ND	14	0	15	Corrosion of household plumbing systems, erosion of natural deposits

⁴ The 90th percentile level of all samples is the number used to determine if Camp Lejeune is in compliance with Federal, State, and DoW guidance.

Lead, Copper, and Drinking Water

The table above summarizes our most recent lead and copper tap sampling data. If you would like to review the complete lead tap sampling data, please contact David Towler at 910-451-9385.

Exposure to lead in drinking water can cause serious health effects in all age groups. Infants and children can have decreases in IQ and attention span. Lead exposure can lead to new learning and behavior problems or exacerbate existing learning and behavior problems. The children of women who are exposed to lead before or during pregnancy can have increased risk of these adverse health effects. Adults can have increased risk of heart disease, high blood pressure, kidney or nervous system problems.

Lead can cause serious health problems, especially for pregnant women and young children. Lead in drinking water is primarily from materials and components associated with service lines and home plumbing. Camp Lejeune is responsible for providing high quality drinking water and removing lead pipes, but cannot control the variety of materials used in plumbing components in your home. You share the responsibility for protecting yourself and your family from the lead in your home plumbing. You can take responsibility by identifying and removing lead materials within your home plumbing and taking steps to reduce your family's risk. Before drinking tap water, flush your pipes for several minutes by running your tap, taking a shower, doing laundry or a load of dishes. You can also use a filter certified by an American National Standards Institute accredited certifier to reduce lead in drinking water. If you are concerned about lead in your water and wish to have your water tested, contact Camp Lejeune Environmental Management Division at 910-451-5003. Information on lead in drinking water, testing methods, and steps you can take to minimize exposure is available at: <https://www.epa.gov/safewater/lead>

A **drinking water service line inventory (SLI)** has been completed for the Hadnot Point water system. Based on available data and records, Camp Lejeune has verified that there is no indication of any lead service lines being installed in the Hadnot Point water system. The Hadnot Point SLI along with additional information about lead and drinking water can be found at:

[Lead and drinking water additional information](#)

Help Protect Your Water

Protection of drinking water is everyone's responsibility. You can help protect our drinking water sources in several ways: dispose of chemicals properly, take used motor oil to recycling centers, volunteer to participate in group efforts to protect our water sources, etc.

Voluntary Sampling Program

In addition to what is required by regulation, and as part of our commitment to ensure that we are providing the safest, most reliable drinking water possible, Camp Lejeune has monitored drinking water for substances found in explosives (nitroaromatics, nitramines, nitrate esters) and perchlorate in finished water since 2004, and raw groundwater starting in 2011. These substances, commonly known as "munitions constituents", are used in the manufacture of explosives or are the breakDoWn products of compounds used in explosives. Voluntary water sampling in 2025 detected trace amounts of one munitions constituent in the finished water. These trace amounts are not a health concern. There are no MCLs established for munitions constituents.

Additionally, Camp Lejeune sampled both raw groundwater and finished water for Volatile Organic Compounds, Synthetic Organic Compounds, Inorganic Compounds, and Per- and polyfluorinated Alkyl Substances (PFAS). This sampling was done voluntarily above what is required by current regulations and Department of War (DoW) requirements. Results of all voluntary testing were within Federal, State, and DoW drinking water guidance.

Detections for voluntary sampling conducted throughout the Hadnot Point water system can be viewed on the web at:

[Camp Lejeune Water Quality Reports](#)

Important Health Information

Some people may be more vulnerable to contaminants in drinking water than the general population. Immuno-compromised persons such as: persons with cancer undergoing chemotherapy, persons who have undergone organ transplants, people with HIV/AIDS or other immune system disorders, some elderly, and infants can be particularly at risk from infections. These people or their parents or guardians should seek advice about drinking water from health care providers. EPA/Centers for Disease Control (CDC) guidelines on appropriate means to lessen infection by Cryptosporidium and other microbial contaminants are available from the Safe Drinking Water Hotline (800-426-4791).

Per- and polyfluoroalkyl Substances (PFAS)

What are per- and polyfluoroalkyl substances and where do they come from?

Per- and polyfluoroalkyl substances (PFAS) are a group of thousands of man-made chemicals. PFAS have been used in a variety of industries and consumer products around the globe, including the United States, since the 1940s. PFAS are found in many consumer products, as well as in industrial products, like certain firefighting agents called aqueous film forming foam (AFFF). PFAS is also found in essential use applications such as microelectronics, batteries, and medical equipment. PFAS chemicals are persistent in the environment, and some are persistent in the human body - meaning they do not break down and they can accumulate over time.

Is there a federal or North Carolina state regulation for PFAS in drinking water?

On April 26, 2024, the United States Environmental Protection Agency (EPA) published a National Primary Drinking Water Regulation (NPDWR) final rule on drinking water standards for six PFAS under the Safe Drinking Water Act (SDWA). The rule establishes the following Maximum Contaminant Levels (MCLs). See table below.

Compound	Final MCLG	Final MCL (enforceable levels)
Perfluorooctanoic acid (PFOA)	0	4.0 ppt
Perfluorooctane sulfonic acid (PFOS)	0	4.0 ppt
Perfluorohexane sulfonic acid (PFHxS)	10 ppt	10 ppt
Perfluorononanoic acid (PFNA)	10 ppt	10 ppt
HFPO-DA (commonly known as Gen-X)	10 ppt	10 ppt
Mixtures containing two or more of: PFHxS, PFNA, HFPO-DA, and PFBS	1 (unitless) Hazard Index (HI)	1 (unitless) HI

ppt = parts per trillion or nanograms per liter (ng/L)

$$HI\ MCL = \left(\frac{[HFPO-DA_{water}]}{[10\ ppt]} \right) + \left(\frac{[PFBS_{water}]}{[2000\ ppt]} \right) + \left(\frac{[PFNA_{water}]}{[10\ ppt]} \right) + \left(\frac{[PFHxS_{water}]}{[10\ ppt]} \right) = 1$$

Under the NPDWR, regulated public water systems (PWS) are required to complete initial monitoring by April 26, 2027. Beginning April 26, 2027, regulated PWSs will conduct ongoing compliance monitoring in accordance with the frequency dictated by the rule and as determined by the initial compliance monitoring results. Regulated PWSs must demonstrate compliance with the Maximum Contaminant Levels (MCLs) by April 26, 2029.

In order to provide safe drinking water to all DoW personnel, the Office of the Secretary of War (OSW) policy extends this requirement to all DoW systems which provide drinking water for human consumption, regardless of size of the drinking water system. In addition to the six regulated compounds, DoW-owned systems are required by DoW policy to monitor for all 25 compounds detected when using EPA Method 533.

Protecting the health of our personnel, their families, and the communities in which we serve is a priority for the Department. DoW is committed to complying with requirements of the NPDWR and the continued provision of safe drinking water to those that work and live on DoW installations.

Has Camp Lejeune tested its water for PFAS?

Yes. In May and October 2025, samples were collected from the Hadnot Point water distribution system. We are pleased to report that drinking water testing results for all 25 PFAS covered by the sampling method, including the six regulated PFAS, were not detected in your water system.

What is next?

Camp Lejeune's initial monitoring for PFAS in accordance with EPA requirements is complete. Based on these results, the installation will begin triennial monitoring for PFAS in 2027.

Substances That Could Be in the Water

To ensure that tap water is safe to drink, EPA prescribes regulations which limit the amount of certain contaminants in water provided by public water systems. U.S. Food and Drug Administration regulations establish limits for contaminants in bottled water, which must provide the same protection for public health. Drinking water, including bottled water, may reasonably be expected to contain at least small amounts of some contaminants. The presence of contaminants does not necessarily indicate that water poses a health risk. The sources of drinking water (both tap water and bottled water) include rivers, lakes, streams, ponds, reservoirs, springs, and wells. As water travels over the surface of the land or through the ground, it dissolves naturally occurring minerals and, in some cases, radioactive material, and can pick up and transport substances (contaminants) resulting from the presence of animals or from human activity.

Substances that may be present in the water include:

Microbial Contaminants, such as viruses and bacteria, which may come from sewage treatment plants, septic systems, agricultural livestock operations and wildlife;

Inorganic Contaminants, such as salts and metals, which can occur naturally in the soil or groundwater or may result from urban stormwater runoff, industrial or domestic wastewater discharges, oil or gas production, mining, or farming;

Pesticides and Herbicides, which may come from a variety of sources such as agriculture, urban stormwater runoff, and residential uses;

Organic Chemical Contaminants, including synthetic and volatile organic compounds, which are byproducts of industrial processes and petroleum production, and can also come from gas stations, urban stormwater runoff, and septic systems;

Radioactive Contaminants, which can occur naturally or be the result of oil and gas production and mining activities.

More information about contaminants and potential health effects can be obtained by contacting the Environmental Protection Agency by calling the Safe Drinking Water Hotline (1-800-426-4791) or visiting the website:

<https://www.epa.gov/ground-water-and-drinking-water>.

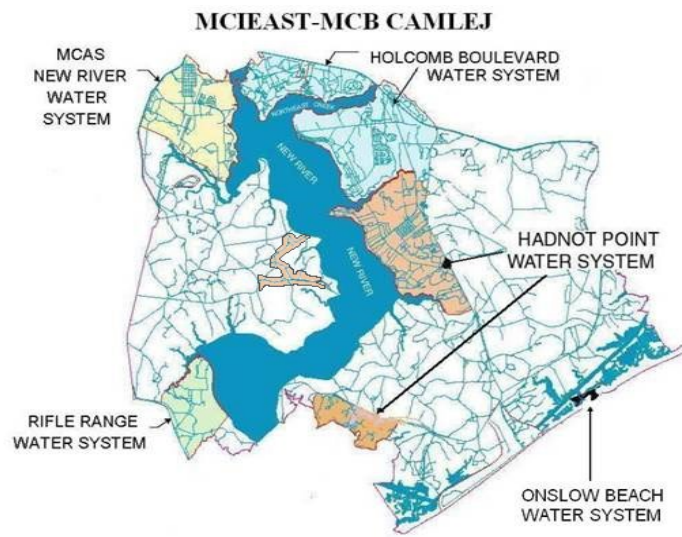



SOURCE WATER ASSESSMENT PROGRAM (SWAP) RESULTS

The North Carolina Department of Environmental Quality (NCDEQ), Public Water Supply Section (PWSS), Source Water Assessment Program (SWAP) conducted assessments for all drinking water sources across North Carolina. The purpose of the assessments was to determine the susceptibility of each drinking water source (wells) to Potential Contaminant Sources (PCSs). The results of the assessment are available in SWAP reports that include maps, background information, and a relative susceptibility rating of Higher, Moderate or Lower. The relative susceptibility rating of each source for the Hadnot Point Water Treatment System was determined by combining the contaminant rating (number and location of PCSs within the assessment area) and inherent vulnerability rating (i.e., characteristics or existing conditions of the well or watershed and its delineated assessment area). The assessment findings based on the SWAP report completed on September 10, 2020 are summarized in the table below:

Hadnot Point Drinking Water Supply Wells	
Source Name	Susceptibility Rating
585	Moderate
595	Lower
596	Lower
606	Moderate
607	Moderate
611	Lower
612	Lower
614	Lower
621	Moderate
622	Moderate
627	Moderate
630	Lower
632	Lower
640	Moderate
641	Higher
652	Lower
661	Moderate
662	Lower
663	Lower
668	Lower
669	Moderate
684	Lower
685	Moderate
686	Lower
688	Lower
709	Moderate
710	Moderate
711	Moderate
5186	Higher

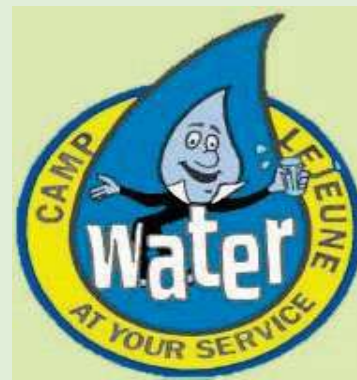

System Name: USMC Lejeune
- Hadnot Point
PWS ID: 0467041

To obtain a copy of the complete SWAP report for the Hadnot Point Water Treatment System request a copy from NCDEQ at swap@deq.nc.gov.

It is important to note that susceptibility ratings do not imply higher or lower water quality, only the systems's potential to become contaminated by PCSs in the assessment area.

Hadnot Point Water Treatment Process

As the raw water enters the water treatment plant, sodium hypochlorite is added to protect against microbial contamination, and the water is placed into a large storage tank called a reservoir. From the storage reservoir the water is pumped to a set of large, cone-shaped devices called spiractors. The spiractors are used to soften the water by removing minerals. Lime is added at the bottom of the spiractors to aid the softening process. The water is then passed through a set of filters, which contain layers of sand and carbon, to remove particles through a process called filtration. Fluoride (to prevent tooth decay) is added to the water, and then the clean water is placed in a storage reservoir. When water is needed by customers, it is pumped from the storage reservoirs and distributed throughout the Hadnot Point community water system.

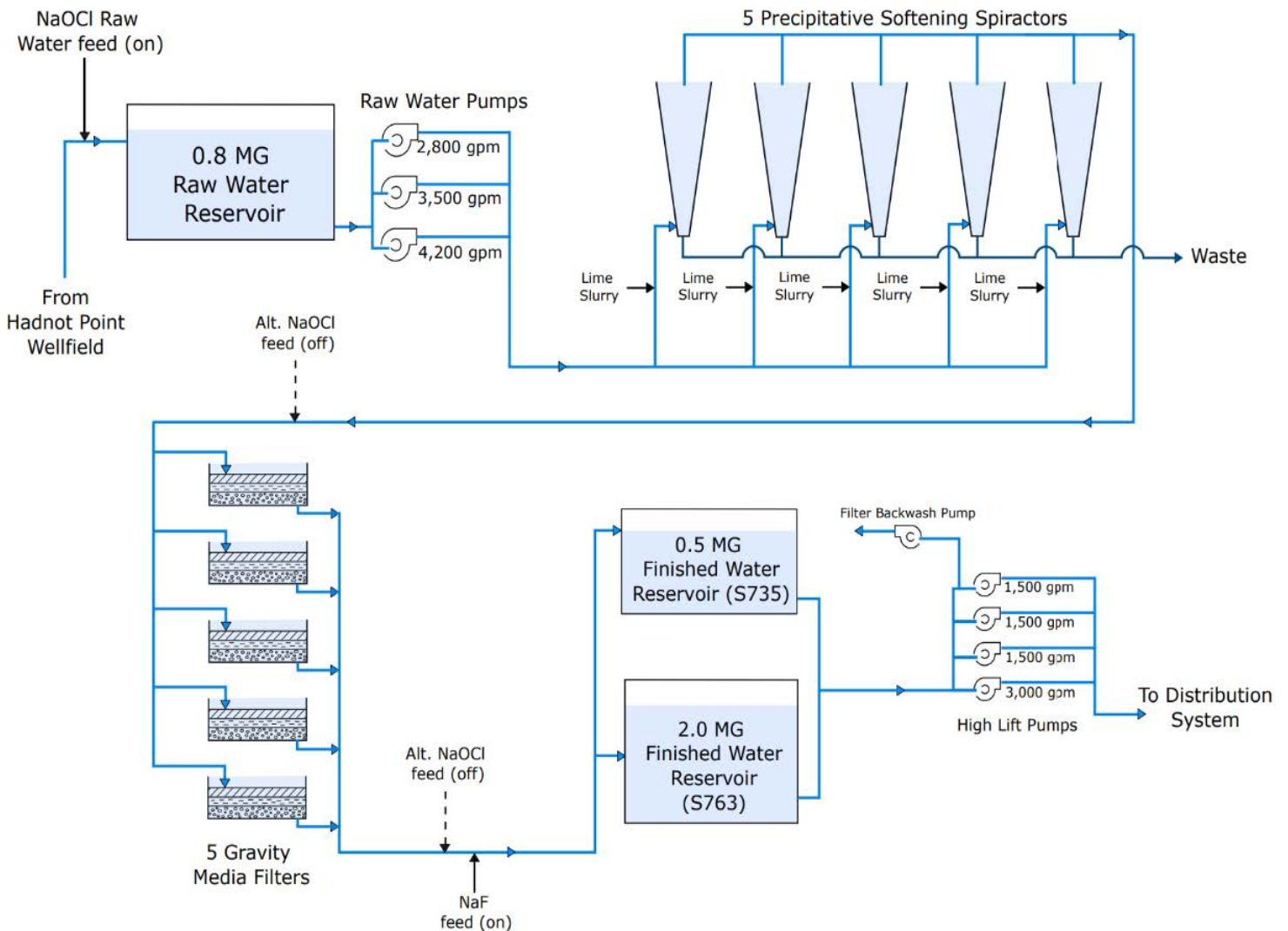

Plant Capacity = 5.0 MGD

WATER CONSERVATION

Did you know that the average U.S. household uses approximately 400 gallons of water per day or 100 gallons per person per day? You can play a role in conserving water by becoming conscious of the amount of water your household is using and by looking for ways to use less whenever possible. It is not hard to conserve water. Small changes can make a big difference. Here are a few tips:

- Take short showers – a 5 minute shower uses 4 to 5 gallons of water compared to up to 50 gallons for a bath.
- Run your clothes washer and dishwasher only when they are full. You can save up to 1,000 gallons a month.
- Shut off water while brushing your teeth, washing your hair and shaving and save up to 500 gallons a month.
- Check every faucet in your home for leaks. Just a slow drip can waste 15-20 gallons a day.
- Check your toilets for leaks by putting a few drops of food coloring in the tank. Watch for a few minutes to see if the color shows up in the bowl. It is not uncommon to lose up to 100 gallons a day from an invisible toilet leak.
- Use a water-efficient showerhead. They're inexpensive, easy to install, and can save you up to 750 gallons a month.
- Water plants only when necessary and adjust sprinklers so only your lawn is watered. Apply water only as fast as the soil can absorb it and during the cooler parts of the day to reduce evaporation.
- Don't run the hose while washing your car. Use a bucket of water and a quick hose rinse at the end or wash vehicles at a carwash that recycles its water. Saves 150 gallons each time.

Teach your kids about water conservation to ensure a future generation that uses water wisely.

Visit www.epa.gov/watersense for more information.

Remember, when you conserve water you also conserve energy!

